

TPRT

マシン用テーパピンリーマー

Machine Taper Pin Reamer

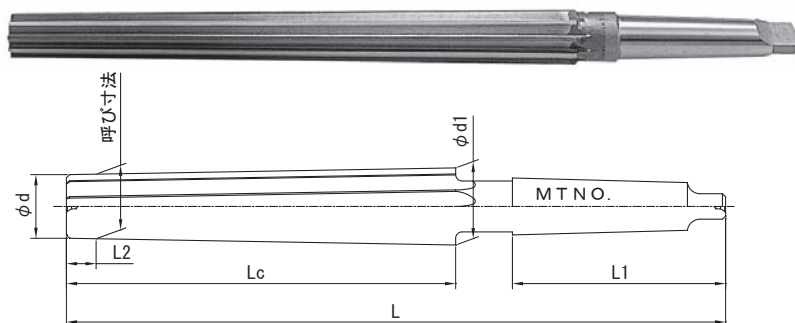

SKH51 1/50テーパ

呼び寸法	柄径	刃長	全長	柄長	小径	太径	先端から 呼び寸法まで	刃数
	MT	L c	L	L 1	φ d	φ d 1	L 2	
5	MT1	87	165	65.5	4.9	6.44	5	6
6	MT1	99	180	65.5	5.9	7.88	5	6
7	MT1	119	200	65.5	6.9	9.28	5	6
8	MT1	141	222	65.5	7.9	10.72	5	6
9	MT1	163	245	65.5	8.9	12.16	5	8
10	MT1	163	245	65.5	9.9	13.16	5	8
11	MT1	163	245	65.5	10.9	14.16	5	8
12	MT2	194	295	78.5	11.86	15.74	7	8
13	MT2	194	295	78.5	12.86	16.74	7	8
14	MT2	194	295	78.5	13.86	17.74	7	8
15	MT2	234	335	78.5	14.84	19.52	8	8
16	MT2	234	335	78.5	15.84	20.52	8	8
17	MT2	234	335	78.5	16.84	21.52	8	8
18	MT2	234	335	78.5	17.84	22.52	8	8
19	MT2	270	370	78.5	18.8	24.2	10	8
20	MT2	270	370	78.5	19.8	25.2	10	8
21	MT2	270	370	78.5	20.8	26.2	10	8
22	MT2	270	370	78.5	21.8	27.2	10	8
23	MT3	310	430	98	22.74	28.94	13	10
24	MT3	310	430	98	23.74	29.94	13	10
25	MT3	310	430	98	24.74	30.94	13	10
26	MT3	310	430	98	25.74	31.94	13	10
27	MT3	310	430	98	26.74	32.94	13	10
28	MT3	318	445	98	27.7	34.06	15	10
29	MT3	318	445	98	28.7	35.06	15	10
30	MT3	318	445	98	29.7	36.06	15	10
32	MT3	318	445	98	31.7	38.06	15	10
33	MT4	335	500	123	32.6	39.3	20	12
34	MT4	335	500	123	33.6	40.3	20	12
35	MT4	335	500	123	34.6	41.3	20	12
36	MT4	335	500	123	35.6	42.3	20	12
38	MT4	335	500	123	37.6	44.3	20	12
40	MT4	335	500	123	39.6	46.3	20	12
42	MT4	335	500	123	41.6	48.3	20	12
45	MT4	351	525	123	44.5	51.52	25	14
50	MT4	351	525	123	49.5	56.52	25	14

被削材種 型番	鋳物	炭素鋼	合金鋼	工具鋼	調質鋼	ステンレス鋼	アルミ合金	銅合金	チタン合金	耐熱合金
	FC, FCD	S45C	SCM	SKD	NAK, HPM	SUS	Al	Cu	Ti6Al4V	インコネル
硬度	~200HB	~200HB	~250HB	~35HRC	~45HRC					
TPRT	○	○	○				○			

切削条件 P.302 シャンク部形状 P.307